

**MicroPower™ Microprocessor Reset Circuit**

**General Description**

The AAT3532 PowerManager is a member of Skyworks' Total Power Management IC (TPMIC™) product family. It is a fully integrated device for monitoring microprocessor activity, external reset, and power supply conditions. The device holds the microprocessor in a reset condition for a minimum of 250ms while  $V_{CC}$  is established to ensure correct system start-up. A manual reset can be initiated via a de-bounced input pin. As an additional level of protection, the AAT3532 includes a watchdog timer which requires a periodic strobe input from the microprocessor to ensure correct operation. The AAT3532 has a programmable watchdog timer and voltage tolerance level. The quiescent supply current is extremely low, typically 23 $\mu$ A.

The AAT3532 is available in a Pb-free, 8-pin SOP package and is specified over the -40°C to +85°C temperature range.

**Features**

- Adjustable 4.5V or 4.75V Voltage Monitor
- 250ms (min) Reset Pulse Width
- Low Quiescent Current: Typically 23 $\mu$ A
- Adjustable Watchdog Timer (150ms, 600ms, or 1200ms)
- De-bounced Manual Reset Input
- Operates Down to 20ns Strobe Input Pulse Width
- No External Components
- Temperature Range: -40° to +85°C
- Standard 8-Pin SOP Package
- Pin Compatible with MAX1232

**Applications**

- Automotive
- Computers
- Controllers
- Embedded Systems
- Intelligent Instrumentation
- Telecom Equipment

**Typical Application**

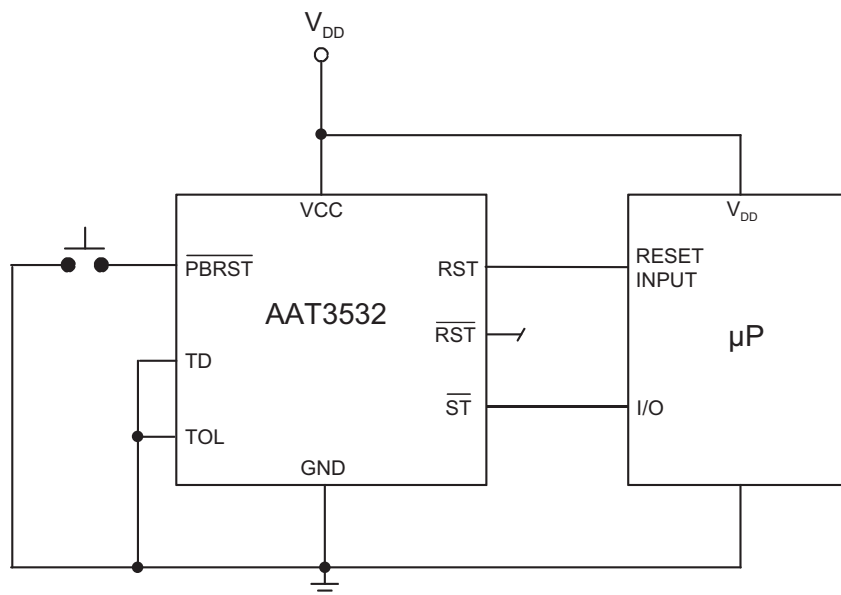

## Pin Descriptions

Pin #	Symbol	Function
1	$\overline{\text{PBRST}}$	Push-button reset input. A de-bounced active low input for manual reset. Guaranteed to recognize inputs 20ms or greater.
2	TD	Watchdog time delay set input. See Table 1 for watchdog timeout selections.
3	TOL	Tolerance set. Input selects 5% or 10% threshold detection.
4	GND	IC ground connection.
5	RST	Reset output (active high). Activated when either: $V_{CC}$ falls below the reset voltage threshold; $\overline{\text{PBRST}}$ is forced low; $\overline{\text{ST}}$ is not strobed within the minimum timeout period; or during power-up.
6	$\overline{\text{RST}}$	Reset output (active low, open drain). Inverse of RST.
7	$\overline{\text{ST}}$	Strobe input to watchdog timer. A pulse is required within the watchdog timeout period to prevent $\overline{\text{RST}}$ and RST entering active state.
8	VCC	5V supply.

## Pin Programming Selections

TD Pin	Timeout		
	Min	Typ	Max
GND	62.5ms	150ms	250ms
Float	250ms	600ms	1000ms
$V_{CC}$	500ms	1200ms	2000ms

**Table 1: TD Pin Programming for Watchdog Timeout Selections.**

TOL Pin	Tolerance
$V_{CC}$	10%
GND	5%

**Table 2: Reset Voltage Threshold Programming Selections.**

## Pin Configuration

### SOP-8 (Top View)

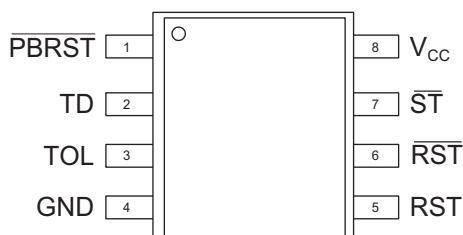

**Absolute Maximum Ratings<sup>1</sup>**

$T_A = 25^\circ\text{C}$ , unless otherwise noted.

Symbol	Description	Value	Units
$V_{CC}$	$V_{CC}$ to GND	-0.5 to 6	V
$V_{I/O}$	Voltage on I/O Pins Relative to GND	-0.5 to ( $V_{CC}+0.5$ )	V
$T_A$	Operating Temperature Range	-40 to 85	$^\circ\text{C}$
$T_S$	Storage Temperature Range	-65 to 150	$^\circ\text{C}$
$T_{LEAD}$	Maximum Soldering Temperature (at leads, 10 sec.)	300	$^\circ\text{C}$
$V_{ESD}$	ESD Rating <sup>2</sup> —HBM	2000	V

**Thermal Characteristics<sup>3</sup>**

Symbol	Description	Value	Units
$\Theta_{JA}$	Maximum Thermal Resistance	100	$^\circ\text{C}/\text{W}$
$P_D$	Maximum Power Dissipation	1.25	W

1. Stresses above those listed in Absolute Maximum Ratings may cause permanent damage to the device. Functional operation at conditions other than the operating conditions specified is not implied. Only one Absolute Maximum Rating should be applied at any one time.

2. Human body model is a 100pF capacitor discharged through a 1.5k $\Omega$  resistor into each pin.

3. Mounted on an FR4 board.

## MicroPower™ Microprocessor Reset Circuit

## DC Electrical Characteristics

$V_{IN} = 4.5V$  to  $5.5V$ ,  $T_A = -40^{\circ}C$  to  $+85^{\circ}C$ , unless otherwise noted. Typical values are  $T_A = 25^{\circ}C$ .

Symbol	Description	Conditions	Min	Typ	Max	Units	
$V_{CC}$	Supply Voltage		4.5	5.0	5.5	V	
$I_Q$	Quiescent Current <sup>1</sup>	$V_{CC} = 5.5V$	CMOS Levels		23	50	$\mu A$
			TTL Levels		160	500	
$V_{CCTP}$	Reset Threshold 5%	TOL = GND	4.50	4.62	4.74	V	
	Reset Threshold 10%	TOL = $V_{CC}$	4.25	4.37	4.49		
$I_{IL}$	Input Leakage $\overline{ST}$ , TOL		-1.0		1.0	$\mu A$	
$I_{OH}$	Output Current RST <sup>2</sup>	$V_{OH} = 2.4V$	-8.0			mA	
$I_{OL}$	Current RST <sup>2</sup> , $\overline{RST}$	$V_{OL} = 0.4V$	10.0			mA	
$V_{IH}$	$\overline{ST}$ and $\overline{PBRST}$ Input High		2.0		$V_{CC} + 0.3$	V	
$V_{IL}$	$\overline{ST}$ and $\overline{PBRST}$ Input Low		-0.3		0.8	V	
$I_{RST}$	$\overline{RST}$ Output Leakage	$V_{OH} = V_{CC}$			1.0	$\mu A$	

## AC Electrical Characteristics

$V_{IN} = 4.5V$  to  $5.5V$ ,  $T_A = -40^{\circ}C$  to  $+85^{\circ}C$ , unless otherwise noted. Typical values are  $T_A = 25^{\circ}C$ .

Symbol	Description	Conditions	Min	Typ	Max	Units
$C_{IN}$	Input Capacitance $\overline{ST}$ , TOL <sup>3</sup>	$T_A = 25^{\circ}C$			5	pF
$C_{OUT}$	Output Capacitance RST, $\overline{RST}$ <sup>3</sup>	$T_A = 25^{\circ}C$			7	pF
$t_{PB}$	$\overline{PBRST}$ <sup>4</sup>	See Figure 2	20			ms
$t_{PBD}$	$\overline{PBRST}$ Delay	See Figure 2	1	4	20	ms
$t_{RST}$	Reset Active Time		250	610	1000	ms
$t_{ST}$	$\overline{ST}$ Pulse Width	See Figure 3	20			ns
$t_{TD}$	$\overline{ST}$ Time-out Period	TD Pin = 0V	62.5	150	250	ms
		TD Pin = Open	250	600	1000	
		TD Pin = $V_{CC}$	500	1200	2000	
$t_f$	$V_{CC}$ Fall Time <sup>3</sup>	4.75V to 4.25V	10			$\mu s$
$t_r$	$V_{CC}$ Rise Time <sup>3</sup>	4.25V to 4.75V	0	5		$\mu s$
$t_{RPD}$	$V_{CC}$ Detect to RST High and $\overline{RST}$ Low	$V_{CC}$ Falling			50	$\mu s$
$t_{RPU}$	$V_{CC}$ Detect to RST Low and $\overline{RST}$ Open	$V_{CC}$ Rising	250	610	1000	ms

1. Measured with outputs open and  $\overline{ST}$  toggling at 100kHz, 50% duty cycle.

2.  $\overline{RST}$  is an open drain output.

3. Guaranteed by design and not subject to production testing.

4.  $\overline{PBRST}$  must remain low for greater than 20ms to guarantee a reset.

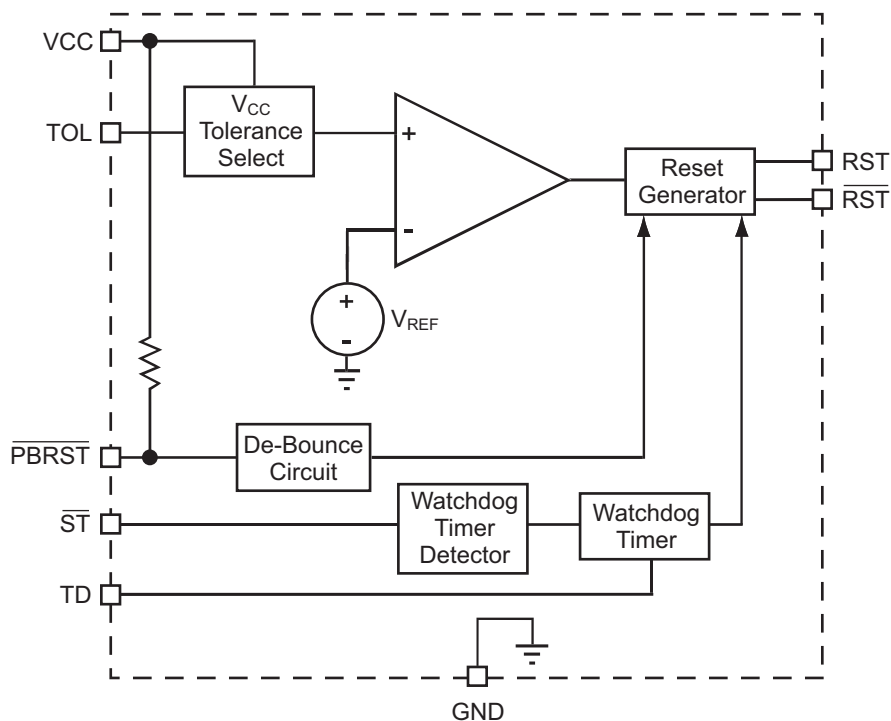
**Functional Block Diagram****Applications Information****Power Monitor**

The reset function monitors the  $V_{CC}$  supply to ensure a microprocessor is correctly reset and is powered up into a known condition following a power supply failure.  $RST$  and  $\overline{RST}$  will remain valid for  $V_{CC}$  voltages down to 1.4V.

The  $RST$  and  $\overline{RST}$  pins are asserted whenever  $V_{CC}$  drops below the reset threshold voltage. This voltage can be set by programming the TOL pin. Connecting TOL to  $V_{CC}$  sets the 10% tolerance of the  $V_{CC}$  supply (typically 4.37V for  $V_{CC} = 5V$ ). Connecting TOL to GND sets the 5% tolerance of the  $V_{CC}$  supply (typically 4.62V for  $V_{CC} = 5V$ ). The reset pin is guaranteed to remain asserted for a minimum period of 250ms after  $V_{CC}$  has risen above the reset threshold voltage. (See Figure 1.)

The  $\overline{RST}$  output is an open drain output. For correct operation, a pull-up resistor of 10k $\Omega$  should be connected between this output and  $V_{CC}$ .

**Manual Reset**

The  $\overline{PBRST}$  pin makes it possible to manually reset the system by either directly connecting a mechanical push-button between the  $\overline{PBRST}$  pin and GND or connecting to a logic low output. Internal de-bounce circuitry is provided to reduce the effect of noise glitches at the input. The signal should remain low for a minimum of 20ms for correct operation. Once the  $\overline{PBRST}$  signal is released (or goes to a logic high), RESET (RESET) remains asserted for a minimum of 250ms.

## MicroPower™ Microprocessor Reset Circuit

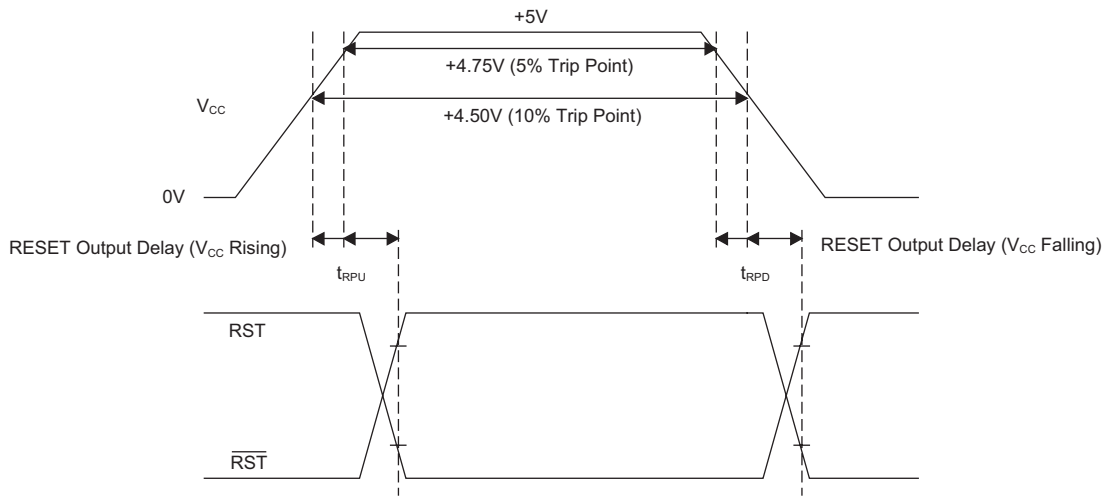

**Figure 1: Reset Output Delay.**

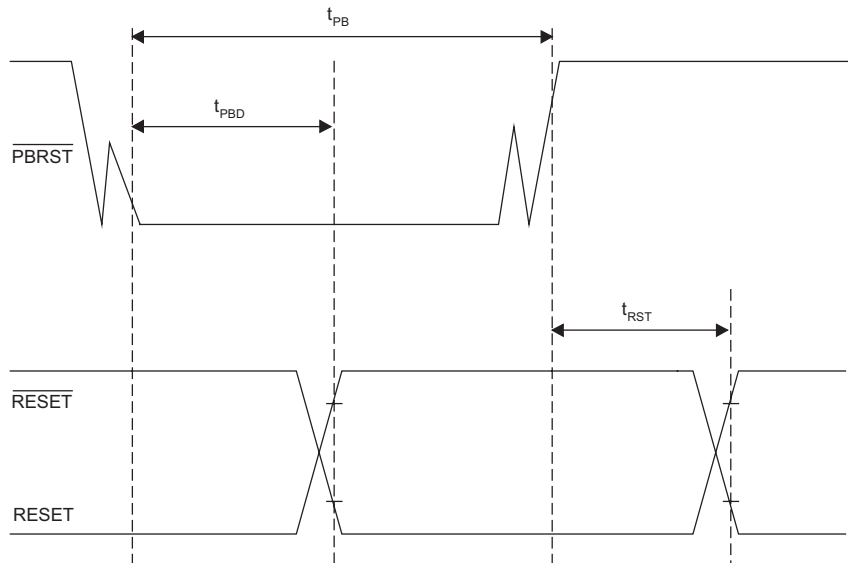

**Figure 2: Push-Button Reset.**

**Watchdog Timer**

The watchdog timer monitors the microprocessor to ensure that the system is functioning correctly. The  $\overline{ST}$  pin of the AAT3532 can be derived from the microprocessor data signals, address signals, and/or I/O signals. The watchdog timer function forces the RST and  $\overline{RST}$  signals into the active state when the  $\overline{ST}$  input is not toggled by a pre-determined time. This time period is set by the logic state of the TD pin, as shown in Table 1. The timer

starts once the RST signals become inactive. If the watchdog timer does not receive a high-to-low transition within the specified timeout period, then the RST signals are activated for a minimum 250ms. In normal operation, the timer should receive a transition from the microprocessor within the timeout period, in which case the timer is reset and normal operation continues.

The AAT3532 will accept and recognize  $\overline{ST}$  pulses down to a minimum of 20ns wide.

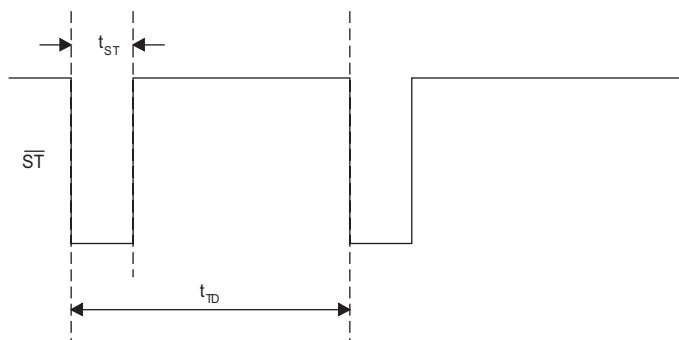

**Figure 3: Watchdog Input.**

**Ordering Information**

Package	Marking	Part Number (Tape and Reel) <sup>1</sup>
SOP-8	3532	<b>AAT3532IAS-T1</b>



Skyworks Green™ products are compliant with all applicable legislation and are halogen-free.

For additional information, refer to *Skyworks Definition of Green™*, document number SQ04-0074.

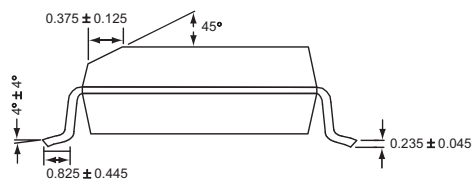
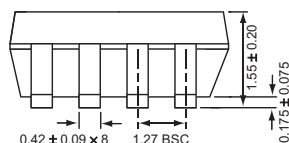
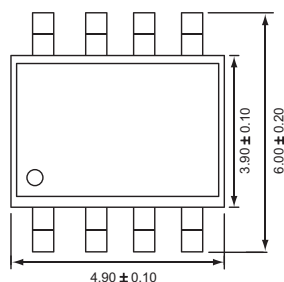
**Package Information****SOP-8**

All dimensions in millimeters.

1. Sample stock is generally held on all part numbers listed in **BOLD**.

Copyright © 2012 Skyworks Solutions, Inc. All Rights Reserved.

Information in this document is provided in connection with Skyworks Solutions, Inc. ("Skyworks") products or services. These materials, including the information contained herein, are provided by Skyworks as a service to its customers and may be used for informational purposes only by the customer. Skyworks assumes no responsibility for errors or omissions in these materials or the information contained herein. Skyworks may change its documentation, products, services, specifications or product descriptions at any time, without notice. Skyworks makes no commitment to update the materials or information and shall have no responsibility whatsoever for conflicts, incompatibilities, or other difficulties arising from any future changes.

No license, whether express, implied, by estoppel or otherwise, is granted to any intellectual property rights by this document. Skyworks assumes no liability for any materials, products or information provided hereunder, including the sale, distribution, reproduction or use of Skyworks products, information or materials, except as may be provided in Skyworks Terms and Conditions of Sale.

THE MATERIALS, PRODUCTS AND INFORMATION ARE PROVIDED "AS IS" WITHOUT WARRANTY OF ANY KIND, WHETHER EXPRESS, IMPLIED, STATUTORY, OR OTHERWISE, INCLUDING FITNESS FOR A PARTICULAR PURPOSE OR USE, MERCHANTABILITY, PERFORMANCE, QUALITY OR NON-INFRINGEMENT OF ANY INTELLECTUAL PROPERTY RIGHT; ALL SUCH WARRANTIES ARE HEREBY EXPRESSLY DISCLAIMED. SKYWORKS DOES NOT WARRANT THE ACCURACY OR COMPLETENESS OF THE INFORMATION, TEXT, GRAPHICS OR OTHER ITEMS CONTAINED WITHIN THESE MATERIALS. SKYWORKS SHALL NOT BE LIABLE FOR ANY DAMAGES, INCLUDING BUT NOT LIMITED TO ANY SPECIAL, INDIRECT, INCIDENTAL, STATUTORY, OR CONSEQUENTIAL DAMAGES, INCLUDING WITHOUT LIMITATION, LOST REVENUES OR LOST PROFITS THAT MAY RESULT FROM THE USE OF THE MATERIALS OR INFORMATION, WHETHER OR NOT THE RECIPIENT OF MATERIALS HAS BEEN ADVISED OF THE POSSIBILITY OF SUCH DAMAGE.

Skyworks products are not intended for use in medical, lifesaving or life-sustaining applications, or other equipment in which the failure of the Skyworks products could lead to personal injury, death, physical or environmental damage. Skyworks customers using or selling Skyworks products for use in such applications do so at their own risk and agree to fully indemnify Skyworks for any damages resulting from such improper use or sale.

Customers are responsible for their products and applications using Skyworks products, which may deviate from published specifications as a result of design defects, errors, or operation of products outside of published parameters or design specifications. Customers should include design and operating safeguards to minimize these and other risks. Skyworks assumes no liability for applications assistance, customer product design, or damage to any equipment resulting from the use of Skyworks products outside of stated published specifications or parameters.

Skyworks, the Skyworks symbol, and "Breakthrough Simplicity" are trademarks or registered trademarks of Skyworks Solutions, Inc., in the United States and other countries. Third-party brands and names are for identification purposes only, and are the property of their respective owners. Additional information, including relevant terms and conditions, posted at [www.skyworksinc.com](http://www.skyworksinc.com), are incorporated by reference.